

## THREE-PHASE-ASYNCHRONOUS-MOTOR E3-ASA 250 M 4

IE3UM25M4201

### General data

Type of motor	3~ explosion proof
Type designation	E3-ASA
Frame size	250
Mounting	B5
Frame execution	M
Frame material	Grauguß
Insulationclass	F
Terminal box location	top DE
Terminal box orientation	cable gland to the right side
Weight (kg)	630
Rotation Direction	right /left
Vibration level	A
Balancing method	half key
cooling type	IC411
Executed acc. to noise level	IEC 60034 -1, EN 60079-0/-1 IEC 60034-9

### Influential factors

Duty	S1
Ambient temperature (°C)	-20 up to +40
Height of location (m)	1000

### Electrical specification

Power 1 50Hz (kW)	55
Power 1 60Hz (kW)	63.25
Frequency (Hz)	50/60
Voltage 50Hz (V)	400/690
Voltage 60Hz (V)	460
Voltage tolerance	+/-5%
Connection	$\Delta/Y$
Poles	4
Efficiency 100% 50Hz (%)	94,9
Efficiency 75% 50Hz (%)	95,0
Efficiency 50% 50Hz (%)	94,4
Efficiency 100% 60Hz (%)	95,4
Efficiency 75% 60Hz (%)	95,0
Efficiency 50% 60Hz (%)	94,4
Power factor	0,88
Starting current factor (Ia/In)	8,0
Starting torque factor (Ma/Mn)	2,6
Breakdown torque (Mk/Mn)	2,9
Rated current 50Hz (A)	95,06/55,14
Rated current 60Hz (A)	94,56/54,85
Eff.Cl.50Hz	IE3
Eff.Cl.60Hz	IE3

### Mechanical data

Torque (Nm)	353,70/338,97
Rotation speed (1/min)	1485/1782
Bearing DE	
Bearing NDE	
Mounting of bearing DE	fixed bearing
Mounting of bearing NDE	loose bearing
Bearing lifetime (h)	20000
allow. Radial load (X/2)	6100
allow. Radial load (X0)	6750
allow. Radial load (Xmax)	5450
allow. Axial load	5500
allow. Axial load (V1)	4420
Moment of inertia (kgm <sup>2</sup> )	1,07146

### Motor properties

Color	RAL7030
Paint surface	matt
Protection class	IP55
Cable gland size (cable connection)	2xM50x1,5
Cable gland size (option)	M20x1,5
Cable gland type	Atex
Shaft end (mm)	65 x 140
Shaft material	C45
Specification NDE	Metal fan
Flange	550

### Additional option

Protection winding	PTC 130°C
Atex	II 2G Ex db eb IIC T4 Gb

# Dimension drawings

## Three-Phase-Asynchronous- Motor E3-ASA 250 M 4

### IE3UM25M4201



Die Zeichnung dient lediglich als Skizze um Maße darzustellen. Das gelieferte Produkt kann von dieser Skizze abweichen. Die detaillierte Beschreibung des Produkts befindet sich im Datenabschnitt (Seite 1).  
 The drawing serves only as a sketch to show dimensions. The delivered product may differ from this sketch. The detailed description of the product can be found in the Data section (page 1).

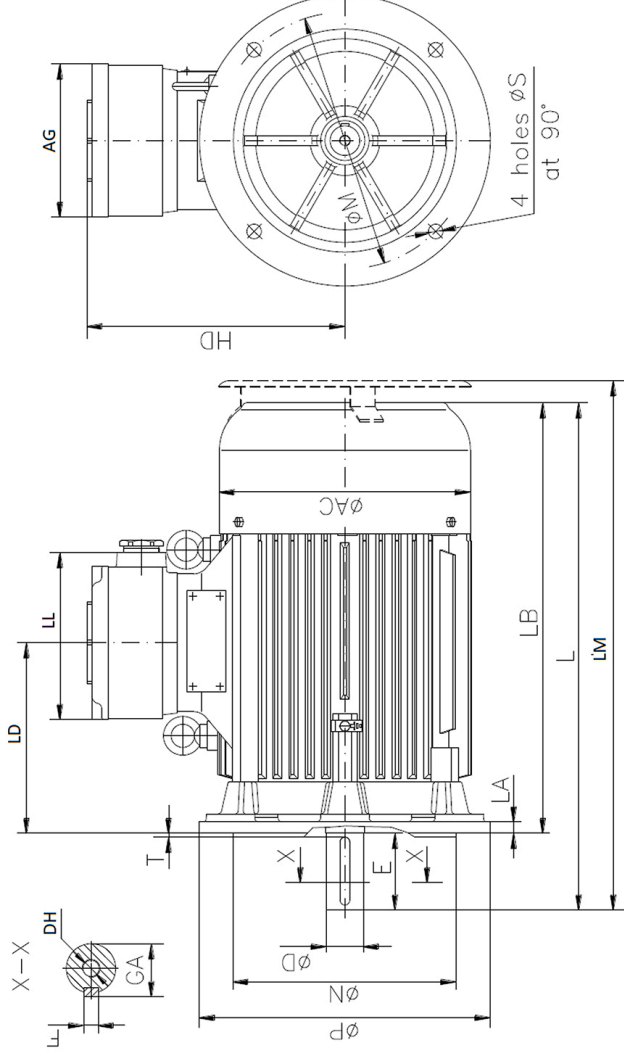

AC	AG	D	E	HD	L	LM	LB	LD	LL	M	N	P	S	T	F	G	DH
446	240	65	140	410	1130	1175	990	275	275	500	450	550	18,5	5	18	69	M20