

## SINGLE-PHASE MOTOR ABS 90 S 4 /HT

AB09S2200001

### General data

Type of motor	1~
Type designation	ABS
Frame size	90
Mounting	B3
Frame execution	S
Frame material	Aluminium
Insulationclass	F/B
Terminal box location	top DE
Terminal box orientation	cable gland to the back side NDE
Weight (kg)	13
Rotation Direction	Clockwise
Vibration level	A
Balancing method	half key
cooling type	IC411
Executed acc. to	IEC 60034-1
noise level	IEC 60034-9

### Influential factors

Duty	S1
Ambient temperature (°C)	-20 up to +40
Height of location (m)	1000

### Electrical specification

Power 1 50Hz (kW)	1.1
Frequency (Hz)	50
Voltage 50Hz (V)	230
Voltage tolerance	+/-10%
Poles	4
Efficiency 100% 50Hz (%)	73,0
Power factor	0,95
Starting current factor (Ia/In)	5,6
Starting torque factor (Ma/Mn)	2,5
Breakdown torque (Mk/Mn)	2,5
Rated current 50Hz (A)	6,90

### Mechanical data

Torque (Nm)	7,50
Rotation speed (1/min)	1400
Bearing DE	6205.ZZ.C3
Bearing NDE	6203.ZZ.C3
Mounting of bearing DE	loose bearing
Mounting of bearing NDE	loose bearing
Bearing lifetime (h)	20000
allow. Radial load (X/2)	775
allow. Radial load (X0)	875

### Mechanical data

allow. Radial load (Xmax)	675
allow. Axial load	675
allow. Axial load (V1)	635
Moment of inertia (kgm <sup>2</sup> )	0,0117

### Motor properties

Color	RAL7030
Paint surface	shiny
Protection class	IP55
Cable gland size (cable connection)	
Cable gland type	Standard
Shaft end (mm)	24 x 50
Shaft material	C45
Specification NDE	Plastic fan

### Motor properties Single-phase

Capacitor	AK+BK
S.C. Capacity	150 myF/300 V
O.C. Capacity	30 myF/450 V
run-up switching	centrifugal switch

# Dimension drawings

## Single-phase motor ABS 90 S 4 /HT

AB09S2200001



Die Zeichnung dient lediglich als Skizze um Maße darzustellen. Das gelieferte Produkt kann von dieser Skizze abweichen. Die detaillierte Beschreibung des Produkts befindet sich im Datenabschnitt (Seite 1).  
 The drawing serves only as a sketch to show dimensions. The delivered product may differ from this sketch. The detailed description of the product can be found in the Data section (page 1).

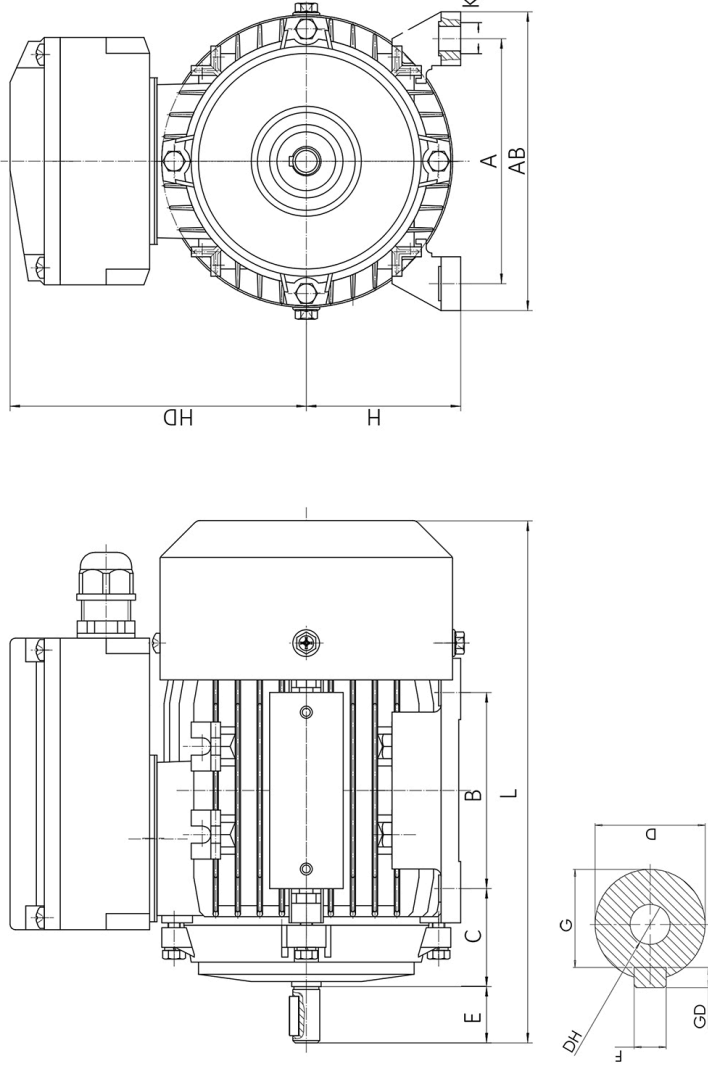

A	AB	B	C	D	E	F	G	H	HD	K	L	F	G	DH
140	180	100	56	24	50	8	20	90	155	10	335	8	20	M8x19