

THREE-PHASE-ASYNCHRONOUS-MOTOR ACA 112 MC 6 /PHE

IE3AC11MC603

General data

Type of motor	3~ progressiv
Type designation	ACA
Frame size	112
Mounting	B3
Frame execution	M
Frame material	Aluminium
Insulationclass	F/B
Terminal box location	top DE
Terminal box orientation	cable gland to the right side
Weight (kg)	38.3
Rotation Direction	right /left
Vibration level	A
Balancing method	half key
cooling type	IC411
Executed acc. to	IEC 60034-1
noise level	IEC 60034-9

Influential factors

Duty	S1
Ambient temperature (°C)	-20 up to +40
Height of location (m)	1000

Electrical specification

Power 1 50Hz (kW)	3
Power 1 60Hz (kW)	3
Frequency (Hz)	50/60
Voltage 50Hz (V)	400/690
Voltage 60Hz (V)	460/795
Voltage tolerance	+/-10%
Connection	Δ/Y
Poles	6
Efficiency 100% 50Hz (%)	85,6
Efficiency 75% 50Hz (%)	85,6
Efficiency 50% 50Hz (%)	83,9
Efficiency 100% 60Hz (%)	89,5
Power factor	0,71
Starting current factor (Ia/In)	6,2
Starting torque factor (Ma/Mn)	2
Breakdown torque (Mk/Mn)	2,1
Rated current 50Hz (A)	7,12/4,13
Rated current 60Hz (A)	5,92/3,44
Eff.Cl.50Hz	IE3
Eff.Cl.60Hz	IE3

Mechanical data

Torque (Nm)	30,32/25,03
Rotation speed (1/min)	945/1145
Bearing DE	6306.ZZ.C3
Bearing NDE	6306.ZZ.C3
Mounting of bearing DE	loose bearing
Mounting of bearing NDE	loose bearing
Bearing lifetime (h)	20000
allow. Radial load (X/2)	1262
allow. Radial load (X0)	1400
allow. Radial load (Xmax)	1125
allow. Axial load	1125
allow. Axial load (V1)	1080
Moment of inertia (kgm ²)	0,02

Motor properties

Color	RAL7030
Paint surface	shiny
Protection class	IP55
Cable gland type	Standard
Shaft end (mm)	28 x 60
Shaft material	C45
Specification NDE	Plastic fan

Additional operating points

Voltage operating point 2	460/795
Power operating point 2 (kW)	3.6
Connection operating point 2	Δ/Y
Frequency operating point 2	60
Efficiency class operating point 2	IE2

Additional option

Protection winding	PTC 150°C
--------------------	-----------

Dimension drawings

Three-Phase-Asynchronous- Motor ACA 112 MC 6 /PHE IE3AC11MC603



Die Zeichnung dient lediglich als Skizze um Maße darzustellen. Das gelieferte Produkt kann von dieser Skizze abweichen. Die detaillierte Beschreibung des Produkts befindet sich im Datenabschnitt (Seite 1).
The drawing serves only as a sketch to show dimensions. The delivered product may differ from this sketch. The detailed description of the product can be found in the Data section (page 1).

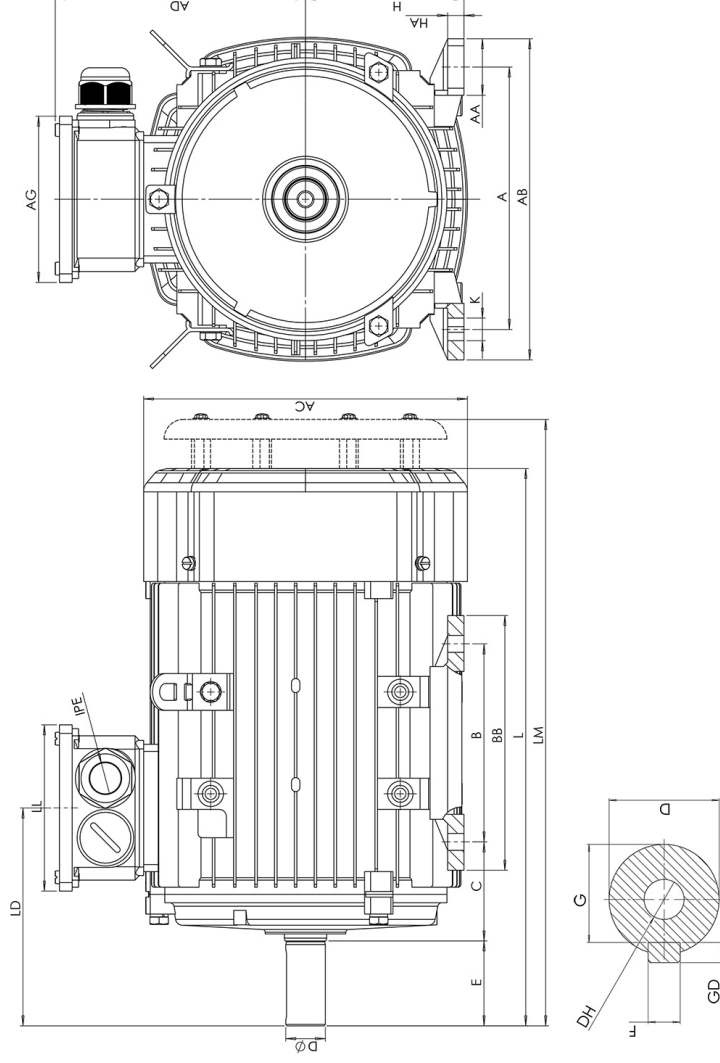

A	AA	AB	AC	AD	AG	B	BB	C	D	E	H	HA	K	L	LM	LD	LL	F	G	DH	EB	ED	GD
190	41	227	219	166	117,5	140	180	70	28	60	112	12	12x16	395	435	151	117,5	8	24	M10x22	50	5	7