

THREE-PHASE-ASYNCHRONOUS-MOTOR FCA 132 M 4/8

AC13M4800003

General data

Type of motor	3~ multi speed
Type designation	FCA
Frame size	132
Mounting	B14a
Frame execution	M
Frame material	Aluminium
Insulationclass	F/B
Terminal box location	top DE
Terminal box orientation	cable gland to the right side
Weight (kg)	79
Rotation Direction	right /left
Vibration level	A
Balancing method	half key
cooling type	IC411
Executed acc. to	IEC 60034-1
noise level	IEC 60034-9

General data double-speed motors

Power 2 50Hz (kW)	1.5
-------------------	-----

Influential factors

Duty	S1
Ambient temperature (°C)	-20 up to +40
Height of location (m)	1000

Electrical specification

Power 1 50Hz (kW)	6.3
Frequency (Hz)	50
Voltage 50Hz (V)	380-420
Voltage tolerance	+/-10%
Connection	YY/Y
Poles	4/8
Efficiency 100% 50Hz (%)	87/81
Power factor	0,89/0,58
Starting current factor (Ia/In)	7,5/5
Starting torque factor (Ma/Mn)	1,8/1,3
Breakdown torque (Mk/Mn)	1,8
Rated current 50Hz (A)	11,74/4,61

Mechanical data

Torque (Nm)	41,78/20,46
Rotation speed (1/min)	1440/700
Bearing DE	6308.ZZ.C3
Bearing NDE	6308.ZZ.C3

Mechanical data

Mounting of bearing DE	loose bearing
Mounting of bearing NDE	loose bearing
Bearing lifetime (h)	20000
allow. Radial load (X/2)	1700
allow. Radial load (X0)	1900
allow. Radial load (Xmax)	1500
allow. Axial load	1450
allow. Axial load (V1)	1400

Motor properties

Color	RAL7030
Paint surface	shiny
Protection class	IP55
Cable gland size (cable connection)	1xM32x1,5 1xblind plug
Cable gland size (option)	M16x1,5
Cable gland type	Standard
Shaft end (mm)	38 x 80
Shaft material	C45
Specification NDE	Plastic fan
Flange	200

Additional option

Protection winding	PTC 150°C
--------------------	-----------

Dimension drawings

Three-Phase-Asynchronous- Motor FCA 132 M 4/8

AC13M4800003



Die Zeichnung dient lediglich als Skizze um Maße darzustellen. Das gelieferte Produkt kann von dieser Skizze abweichen. Die detaillierte Beschreibung des Produkts befindet sich im Datenabschnitt (Seite 1).
 The drawing serves only as a sketch to show dimensions. The delivered product may differ from this sketch. The detailed description of the product can be found in the Data section (page 1).

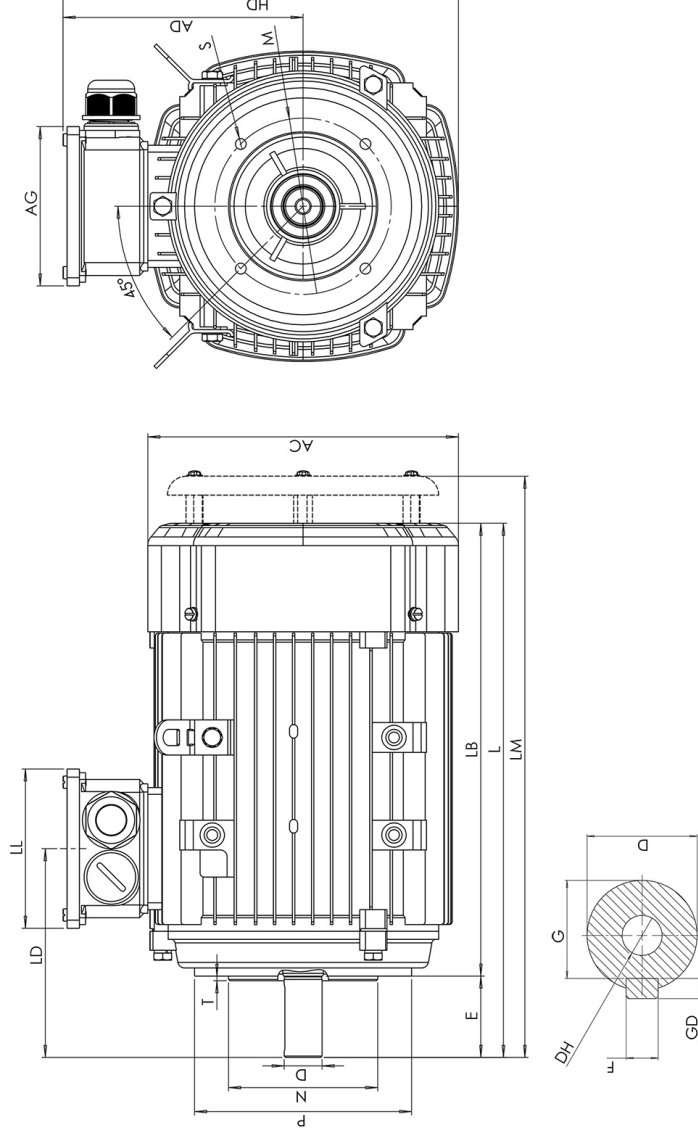

AC	AD	AG	D	E	HD	L	LM	LA	LB	LL	M	N	P	S	T	F	G	DH	EB	ED	GD
258	188	117,5	38	80	317	503	543	14	423	117,5	165	130	200	M10	4	10	33	M12x28	65	7,5	8